

reaction. We therefore must conclude either that the formed hydride **4** is unable to catalyze the oxo reaction, or that another species is formed which is able to catalyze the double bond migration but not the hydroformylation reaction. The latter alternative seems to us the more likely.<sup>25</sup>

(25) It has been suggested by one of the referees that the key step in Reichel and Wrighton's mechanism for the formation of  $\text{HCo}(\text{CO})_3\text{L}$ , namely the formation of a 15-electron species, is inhibited in the presence of a high CO pressure



However, since we do observe isomerization under 80 bar  $\text{CO}/\text{H}_2$  pressure, a different catalytic species must be responsible for the isomerization. A possible candidate is  $\text{R}_3\text{SiCo}(\text{CO})_3$  as discussed by: Reichel, C. L.; Wrighton, M. S. *Inorg. Chem.* 1980, 19, 3858.

## Conclusion

It is expected that UV irradiation of dinuclear cobalt carbonyls produces paramagnetic "reactive" 17 electron species. In fact these species do not seem to be precursors of the hydroformylation catalysts nor do they seem to activate molecular hydrogen or molecular carbon monoxide at synthesis gas pressures up to 85 bar and temperatures up to 85 °C. Thus, it is likely that the intermediates, which are produced photochemically, recombine too fast to allow the macroscopic observation of reactions with CO or  $\text{H}_2$ .

**Acknowledgment.** We would like to thank Dr. Paul Krusic, Du Pont de Nemours, Wilmington, who is independently working on similar problems, for interesting discussions and for making available to us some of his unpublished results.

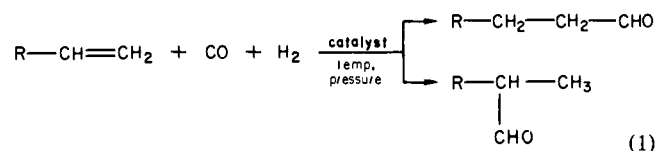
## Photochemical Hydroformylation of Olefins with Cobalt Catalysts. 2. Ionic Cobalt Carbonyls

Manfred J. Mirbach,\* Marlis F. Mirbach, Alfons Saus, Nikolaos Topalsavoglou, and Tuyet Nhu Phu

Contribution from the Universität Duisburg, GH, Fachbereich 6, Angewandte Chemie, D-4100 Duisburg 1, West Germany. Received March 2, 1981.  
Revised Manuscript Received July 10, 1981

**Abstract:** In the presence of  $\text{CO}/\text{H}_2$  or  $\text{CO}$ ,  $\text{H}_2$ , and  $\text{P}(n\text{-Bu})_3$  a methanol solution of cobalt acetate is photochemically reduced to low-valent cobalt carbonyls, which are active catalysts for the hydroformylation of olefins. The hydroformylation of cyclohexene with  $\text{Co}_2(\text{CO})_8$  in methanol is enhanced by UV irradiation, probably via activation of the tetracarbonyl cobaltate ion (**2**) which is formed during the reaction. Similarly in the presence of excess phosphine the  $[\text{Co}(\text{CO})_3(\text{P}(n\text{-Bu})_3)_2][\text{Co}(\text{CO})_4]$  complex (**[1][2]**), which at 80 °C and 80 bar synthesis gas pressure is completely inactive toward hydroformylation, is photochemically converted to  $\text{HCo}(\text{CO})_3\text{P}(n\text{-Bu})_3$  (**4**). **4** is a very selective catalyst for the formation of *n*-aldehydes from  $\alpha$ -olefins. Linear oxo products (99% and 90%) are obtained from propene and octene-1, respectively. In situ IR and UV spectroscopy shows that **4** is mainly produced by photolysis of the cation **1**, and to a lesser extent via photolysis of **2**.

The catalytic hydroformylation (or oxo-reaction) of olefins to aldehydes and alcohols is an outstanding example of a homogeneously catalyzed reaction which is of great commercial importance. Since its discovery by Otto Roelen in Germany in 1937 the reaction has been the subject of innumerable publications and patents.<sup>1</sup>



Cobalt or rhodium carbonyls are commonly used as catalysts. Addition of trialkylphosphines to the cobalt catalyst increases its selectivity toward the more valuable straight-chain products, but relatively high temperatures (150–180 °C) are required to activate the phosphine-modified catalyst. Further developments of this process are directed toward milder reaction conditions and higher selectivities toward the desired *n*-aldehydes or *n*-alcohols.<sup>2</sup>

It is often suggested in the literature that light may be applied to activate homogeneous catalysts. This should allow catalytic processes to be run at lower temperatures and also the conversion of thermally labile molecules (e.g., in a hydroformylation reaction). It has been shown, however, that irradiation of neutral cobalt carbonyls under hydroformylation conditions does *not* lead to higher reaction rates. On the contrary the active catalytic species  $\text{HCo}(\text{CO})_3\text{L}$  ( $\text{L} = \text{CO}$  or  $\text{P}(n\text{-Bu})_3$ ) may even be destroyed photochemically.<sup>3</sup>

In this paper we report that the chemistry is considerably different when ionic cobalt compounds in polar solvents (e.g., methanol) are used as photocatalysts, and that it is indeed possible to hydroformylate olefins photochemically under very mild thermal conditions and with high selectivities toward the desired straight-chain products.<sup>4</sup> The mechanisms of the reactions were investigated by high-pressure IR and UV spectroscopy.

## Experimental Section

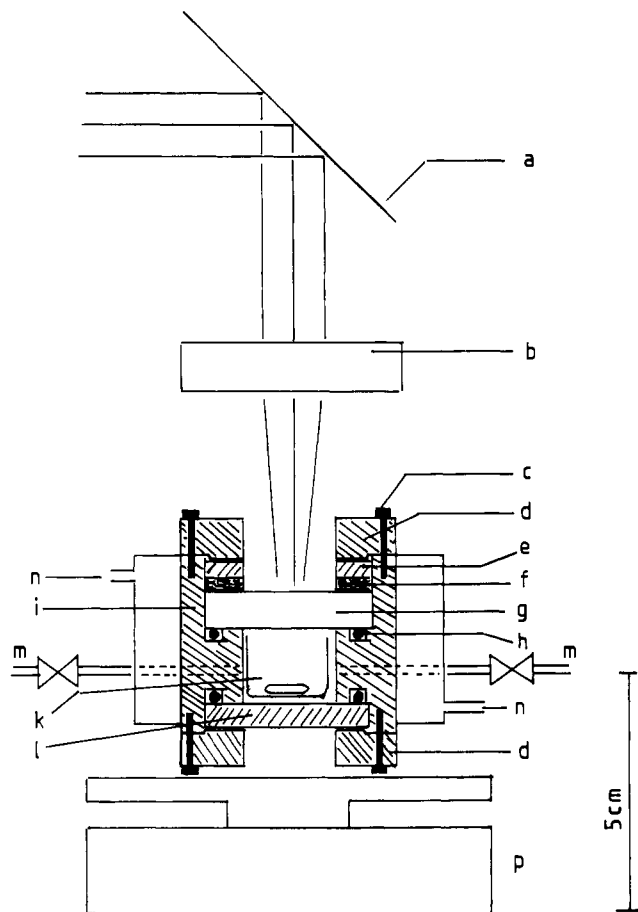
$\text{Co}(\text{OAc})_2 \cdot 4\text{H}_2\text{O}$  (Merck),  $\text{P}(n\text{-Bu})_3$  (EGA-Chemie), octene-1 (EGA-Chemie), propene (Messer-Griesheim), and methanol were used without

(1) For reviews on hydroformylation see: (a) Parshall, G. W. *J. Mol. Catal.* 1978, 4, 243. (b) Falbe, J.; Payer W. In "Ullmann Enzyklopaedie der Technischen Chemie"; Urban & Schwarzenberg: München, 1974; Vol. 7, p 118. (c) Paulik, F. E. *Catal. Rev.* 1972, 6, 49. (d) Falbe, J. "Carbon Monoxide in Organic Synthesis"; Springer: Berlin-Heidelberg-New York, 1970.

(2) (a) Pruett, R. L.; Smith, J. A. U.S. Patent 3917 661, 1975. (b) Cornils, B.; Payer, R.; Traenckner, K. C. *Hydrocarbon Process.* 1975, 83. (c) Siegel, H.; Himmele, W. *Angew. Chem., Int. Ed. Engl.* 1980, 19, 178.

(3) Mirbach, M. J.; Mirbach, M. F.; Saus, A.; Topalsavoglou, N.; Phu, T. N. *J. Am. Chem. Soc.*, preceding paper in this issue.

(4) The qualitative aspects of these experiments were discussed in preliminary accounts: (a) Mirbach, M. J.; Phu, T. N.; Topalsavoglou, N.; Mirbach, M. F.; Saus, A. IUPAC Symposium on Photochemistry, VIII, Seefeld, Austria 1980, Contributed Paper No. 116. (b) Mirbach, M. J.; Phu, T. N.; Topalsavoglou, N.; Saus, A. 2nd International Symposium on Homogeneous Catalysis, Düsseldorf, F.R. Germany, 1980; Abstracts of Papers p 70, (c) Mirbach, M. J.; Mirbach, M. F.; Topalsavoglou, N.; Phu, T. N.; Saus, A. *Angew. Chem.* 1981, 93, 391; *Angew. Chem., Int. Ed. Engl.* 1981, 20, 381.



**Figure 1.** High-pressure cell for determination of photochemical quantum yields: (a) mirror, (b) lens, (c) screws, (d) lid, (e) steel ring, (f) Teflon ring, (g) quartz window, (h) O-ring (Viton B), (i) cell body (stainless steel), (k) glass insert, (l) steel disk, (m) gas inlet and outlet, (n) thermostat inlet and outlet, (p) magnetic stirrer.

further treatment. Drying of the methanol had no influence on the results.

$\text{Co}_2(\text{CO})_8$ ,  $[\text{Co}(\text{P}(n\text{-Bu})_3)_2(\text{CO})_3][\text{Co}(\text{CO})_4]$  and  $\text{Co}_2(\text{CO})_6(\text{P}(n\text{-Bu})_3)_2$  were prepared according to procedures as described in the literature.<sup>5</sup>

The experimental conditions were the same as described before.<sup>3</sup> With methanol as the solvent the aldehydes formed initially may react further in a consecutive acid-catalyzed reaction to give acetals. For the sake of simplicity the yields of the aldehydes and their acetals are added in the results, since they are formed via the same hydroformylation mechanism. It is interesting to note that, even after several hundred hours of irradiation, there is no polymer formation at the glass tube which shields the lamp from the solution.

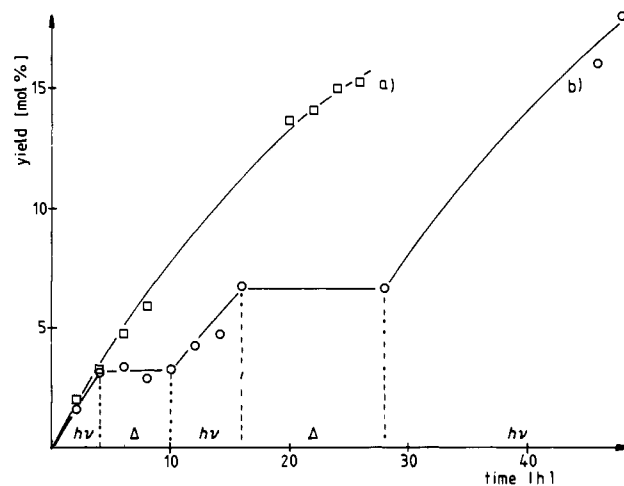
The yields of the metal carbonyl species, taken from the IR and UV spectra, are only relative values. Due to the uncertainties in the extinction coefficients of these compounds absolute concentrations were not determined.

**Quantum Yields.** Quantum yields were determined in a magnetically stirred microautoclave with glass walls using 1 mL of solution (Figure 1). Monochromatic light was produced by selecting the appropriate wavelength with a high-intensity grating monochromator (Schoeffel Instruments) from a 1000 W Hg-Xe source. The light intensity was determined by the Fe-oxalate actinometer.<sup>6</sup>

## Results

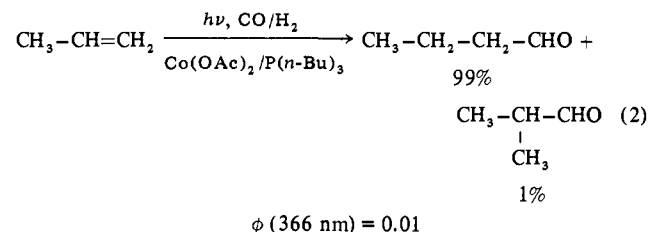
### Hydroformylation of Propene with Co/Phosphine Catalysts.

The hydroformylation of propene produces *n*- and iso-butyraldehyde. At 85 °C and a synthesis gas pressure of 80 bar with a cobalt acetate/tri-*n*-butylphosphine catalyst in methanol the



**Figure 2.** Photochemical hydroformylation of propene. Product yield vs. time (a) with continuous irradiation and (b) with intermittent irradiation. Conditions: 0.017 M  $\text{Co}(\text{OAc})_2$ , 0.18 M  $\text{P}(n\text{-Bu})_3$ , 3 M propene in methanol (total volume 500 mL), 80 °C, 85 bar  $\text{CO}/\text{H}_2 = 1$ , 700 W medium-pressure Hg lamp, Pyrex filter.

photochemical hydroformylation leads to extremely high fractions of *n*-butanal, the *n*/*iso* ratio being better than 99/1. Without irradiation no reaction occurs under these conditions (Table I, Nos. 1 and 2, Figure 2). The reaction is photocatalytic.<sup>7</sup> Figure 2 shows that continuous irradiation is necessary for the formation of products. When the light is turned off the reaction ceases completely. Besides butanal small amounts of methyl butyrate (via a hydroesterification reaction) and dimethyl acetals are formed.



**Hydroformylation of Propene with  $\text{Co}_2(\text{CO})_8$ .** The hydroformylation of propene with unmodified  $\text{Co}_2(\text{CO})_8$  in a methanol solvent occurs much faster than with the  $\text{Co}(\text{OAc})_2$ /phosphine catalyst (Table I, No. 3 and 4). At 60 °C the reaction proceeds at about the same rate as with the phosphine-modified catalyst at 80 °C. The selectivity toward *n*-butanal or acetal, however, is much lower: 52% as compared to 99% in the phosphine-modified case. Neither the rate nor the product distribution is influenced by irradiation, when  $\text{Co}_2(\text{CO})_8$  in methanol is used as the catalyst.

In order to discover the reasons for these fundamental differences between the two catalysts, further experiments with simultaneous IR and UV spectroscopic investigations were made. Octene-1 was selected as a model for an  $\alpha$ -olefin, because its double bond is able to migrate and it is easier to handle and to analyze than propene. Cyclohexene was used as a model compound for an internal olefin.

**Hydroformylation of Octene-1 with Co/Phosphine Catalysts.** The experiments were carried out at temperatures of 75–85 °C

(5) (a) Szabo, P.; Marko, L. *Chem. Tech. (Leipzig)* **1961**, *13*, 549. (b) Manning, A. R. *J. Chem. Soc.* **1968**, 1135.

(6) Parker, C. A. *Proc. R. Soc. London, Ser. A* **1953**, *220*, 104. Hatchard, C. G.; Parker, C. A. *Ibid.* **1956**, *235*, 518. Calvert, J. G.; Pitts, J. N., Jr. "Photochemistry"; Wiley, New-York-London-Sydney, 1966; p 795.

(7) In this paper the term "Photocatalytic" is used when a catalytic reaction is continuously enhanced by UV irradiation. "Photoinitiated" means that irradiation is only necessary at the beginning of the reaction to form the active catalyst. This definition is consistent with that of Strohmeier, who uses the terms "photoaktiviert" and "photoinduziert": Strohmeier, W. *CZ-Chem.-Tech.* **1975**, *4*, 433. Strohmeier, W.; Weigelt, L. *J. Organomet. Chem.* **1977**, *133*, C43. Other authors distinguish between "photocatalytic" and "photoassisted", depending on whether the reaction is catalytic in photons or not, e.g.: Wrighton, M. S. *Chem. Rev.* **1974**, *74*, 401. Hennig, H.; Thomas, P.; Wegener, R.; Wagener, D.; Rehorek, D.; Jurdeczka, K. *Z. Chem.* **1977**, *17*, 241. However, we find it very difficult to decide between the two experimentally and use "photocatalytic" in both cases.

Table I. Photochemical and Thermal Hydroformylation of Olefins with Cobalt Catalysts

no.	olefin	catalyst	time, h	total yield, mol %	product distribution	conditions, °C
1	propene	Co(OAc) <sub>2</sub> /P( <i>n</i> -Bu) <sub>3</sub>	4	3	100% <i>n</i> -butanal	<i>hν</i> , 80 <sup>c</sup>
			24	16	99% <i>n</i> -butanal 1% others	
2	propene	Co(OAc) <sub>2</sub> /P( <i>n</i> -Bu) <sub>3</sub>	36	0	no products	thermal, 80 <sup>c</sup>
			3	3	52% <i>n</i> -butanal <sup>a</sup>	
3	propene	Co <sub>2</sub> (CO) <sub>8</sub>	4	3	33% 2-methylpropanal <sup>a</sup>	<i>hν</i> , 60 <sup>d</sup>
			24	28	14% butyrates	
4	propene	Co <sub>2</sub> (CO) <sub>8</sub>	4	4	53% <i>n</i> -butanal <sup>a</sup>	thermal, 60 <sup>d</sup>
			24	27	31% 2-methylpropanal <sup>a</sup> 16% butyrates	
5	octene-1	Co(OAc) <sub>2</sub>	4	69	59% <i>n</i> -nonanal <sup>a</sup>	<i>hν</i> , 85 <sup>e</sup>
			8	91	32% 2-methyloctanal <sup>a</sup> 9% others <sup>b</sup>	
6	octene-1	Co(OAc) <sub>2</sub>	8	0	59% <i>n</i> -nonanal <sup>a</sup>	thermal, 85 <sup>e</sup>
			22	69	32% 2-methyloctanal <sup>a</sup> 9% others <sup>b</sup>	
7	octene-1	Co <sub>2</sub> (CO) <sub>8</sub>	4	53	61% <i>n</i> -nonanal <sup>a</sup>	<i>hν</i> , 85 <sup>e</sup>
			8	73	29% 2-methyloctanal <sup>a</sup> 10% others <sup>b</sup>	
8	octene-1	Co <sub>2</sub> (CO) <sub>8</sub>	4	63	59% <i>n</i> -nonanal <sup>a</sup>	thermal, 85 <sup>e</sup>
			8	85	30% 2-methyloctanal <sup>a</sup> 11% others <sup>b</sup>	
9	octene-1	Co(OAc) <sub>2</sub> /P( <i>n</i> -Bu) <sub>3</sub>	4	6.5	79% <i>n</i> -nonanal	<i>hν</i> , 85 <sup>f</sup>
			26	33	9% 2-methyloctanal 12% <i>n</i> -octane	
10	octene-1	Co(OAc) <sub>2</sub> /P( <i>n</i> -Bu) <sub>3</sub>	44	0	no products	thermal, 85 <sup>f</sup>
			11	6.5	77% <i>n</i> -nonanal	
11	octene-1	Co <sub>2</sub> (CO) <sub>8</sub> /P( <i>n</i> -Bu) <sub>3</sub>	4	6.5	11% 2-methyloctanal	<i>hν</i> , 85 <sup>g</sup>
			26	32	12% <i>n</i> -octane	
12	octene-1	Co <sub>2</sub> (CO) <sub>8</sub> /P( <i>n</i> -Bu) <sub>3</sub>	44	0	no products	thermal, 85 <sup>g</sup>
			13	1	98% cyclohexanal <sup>a</sup>	
13	cyclohexene	Co(OAc) <sub>2</sub>	4	1	98% cyclohexanal <sup>a</sup>	<i>hν</i> , 80 <sup>h</sup>
			26	33		
14	cyclohexene	Co(OAc) <sub>2</sub>	4	0	98% cyclohexanal <sup>a</sup>	thermal, 80 <sup>h</sup>
			26	0.5		
			88	12		

<sup>a</sup> Mostly as dimethyl acetal. <sup>b</sup> Mostly methyl C<sub>4</sub>-carboxylates. <sup>c</sup> 0.017 M Co(OAc)<sub>2</sub>·4H<sub>2</sub>O, 0.18 M P(*n*-Bu)<sub>3</sub>, 3 M propene in methanol, total volume 500 mL, 85 bar CO/H<sub>2</sub> = 1, 700 W medium-pressure Hg lamp, Pyrex filter. <sup>d</sup> 0.017 M Co<sub>2</sub>(CO)<sub>8</sub>, 3 M propene in methanol, total volume 500 mL, 80 bar CO/H<sub>2</sub> = 1, 700 W medium-pressure Hg lamp, Pyrex filter. <sup>e</sup> 0.0165 M Co, 2.4 M octene-1 in methanol, total volume 500 mL, 80 bar CO/H<sub>2</sub> = 1, 700 W medium-pressure Hg lamp, Pyrex filter. <sup>f</sup> 0.0168 M Co(OAc)<sub>2</sub>·4H<sub>2</sub>O, 0.178 M P(*n*-Bu)<sub>3</sub>, 2.34 M octene-1 in methanol, total volume 500 mL, 80 bar CO/H<sub>2</sub> = 1, 700 W, medium-pressure Hg lamp, Pyrex filter.

and 80 bar synthesis gas pressure (CO/H<sub>2</sub> = 1/1) (Table I, Nos. 9–12).

After 44 h reaction time in the absence of irradiation product had still not been formed, regardless of whether a cobalt acetate/tri-*n*-butylphosphine or a cobalt carbonyl/tri-*n*-butylphosphine starting catalyst was used. When the reaction mixture was irradiated with a medium-pressure mercury lamp through Pyrex the hydroformylation of the olefin proceeded smoothly with a quantum yield of  $\phi_{366\text{ nm}}^{\text{aldehyde}} = 0.01$ . As in the case of propene the selectivity toward straight-chain product (*n*-nonanal) is rather high (*n*/*iso* = 9/1). It is interesting that the product yields with cobalt acetate and with dicobalt octacarbonyl as starting catalysts are nearly identical. During the course of the reaction the octene-1 is slowly isomerized to internal octenes, the hydroformylation of which yields small amounts of branched aldehydes. Another side reaction is the hydrogenation of the olefin to *n*-octane. Hydroformylation, isomerization, and hydrogenation are all photocatalytic, i.e., they are only formed during periods of irradiation.

Irradiation with a low-pressure mercury lamp through quartz gave very similar results.

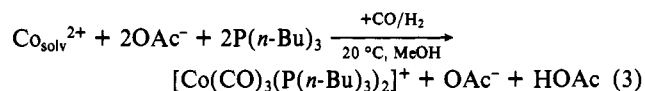
#### IR and UV Investigation of the Co/Phosphine Catalyst

Co(OAc)<sub>2</sub> + P(*n*-Bu)<sub>3</sub>.<sup>8</sup> In order to gain a better understanding of the mechanism of the photochemical hydroformylation, IR and UV spectra were recorded under reaction conditions.

Cobalt acetate (Co(OAc)<sub>2</sub>·4H<sub>2</sub>O) dissolves in methanol to give a pink solution. Small concentrations of phosphine do not affect

the absorption, whereas high concentrations lead to a deep blue color due to complexation of the Co<sup>2+</sup>.<sup>9</sup>

When 80 bar of synthesis gas (CO/H<sub>2</sub> = 1) are added to the pink Co/phosphine solution the color changes immediately to light yellow. In the UV spectrum the color change is accompanied by a disappearance of the weak long wavelength absorption (~600 nm) and by the appearance of a new absorption maximum at 245 nm (Figure 4). Simultaneously two new bands at 1995 and 2000 cm<sup>-1</sup> appear in the IR spectrum (Figure 3). A comparison of these absorptions with those of an authentic sample of [1][2] proves that the cation **1** is already formed at room temperature (eq 3). The spectra of **1** are not altered when the solution is heated

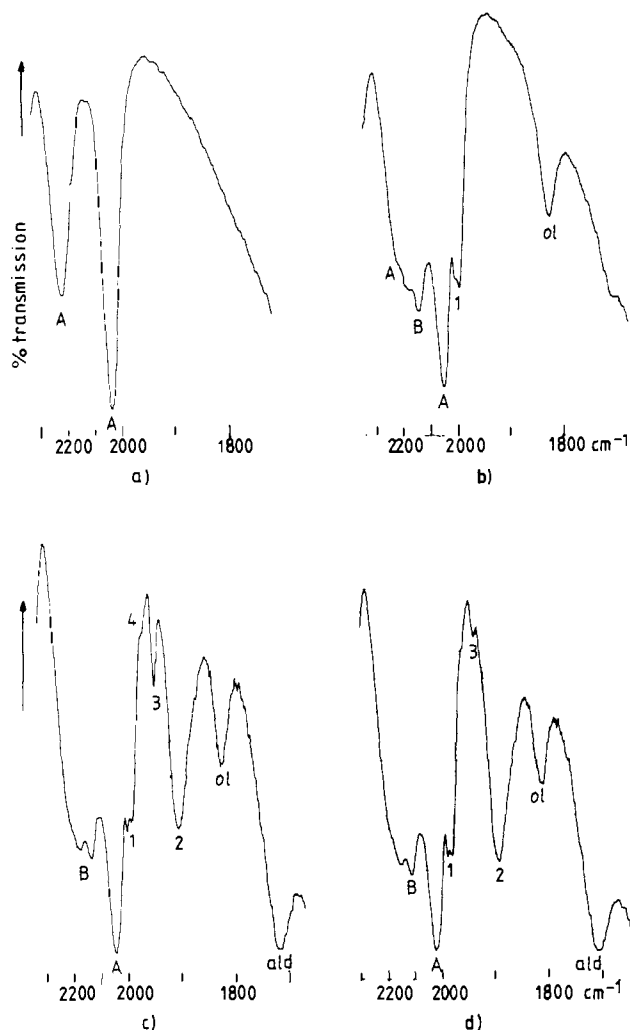


to 80 °C. When the UV irradiation is started, however, a new UV maximum starts to appear at 365 nm and the 245 nm absorption of **1** decreases (Figure 4c). The IR band growing simultaneously at 1950 cm<sup>-1</sup> shows that Co<sub>2</sub>(CO)<sub>6</sub>(P(*n*-Bu)<sub>3</sub>)<sub>2</sub> (**3**) is being formed (Figure 3c). Together with the IR absorption of **3** a broad band appears at 1910 cm<sup>-1</sup> without corresponding UV absorption, which can be assigned to the [Co(CO)<sub>4</sub>]<sup>-</sup> anion **2**.<sup>10</sup> A weak shoulder at 1975 cm<sup>-1</sup> may be due to a small amount

(9) "Gmelin Handbuch der Anorganischen Chemie", 8th ed.; "Kobalt" Erg.-Bd. A; p 373.

(10) Pregelgia, G. F.; Andreetta, A.; Gregorio, G.; Ferrari, G. F.; Montarsi, G.; Ugo, R. *Chim. Ind. (Milan)* 1972, 55, 203.

(8) For a complete assignment of the UV and IR spectra, see ref 3.

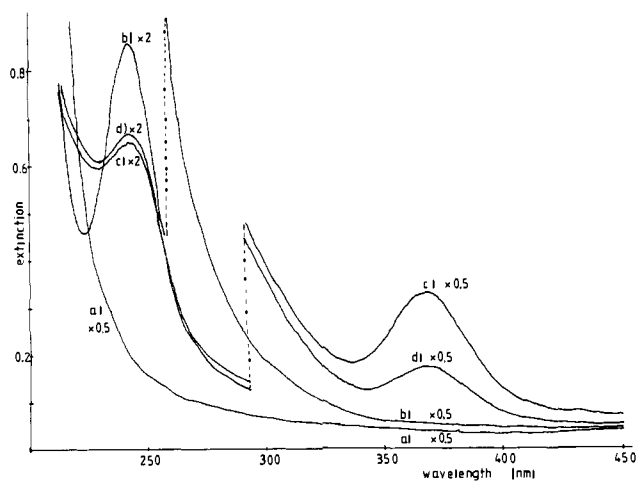


**Figure 3.** IR spectra in the CO stretching region during the hydroformylation of octene-1 with a  $\text{Co}(\text{OAc})_2/\text{P}(n\text{-Bu})_3$  catalyst: (a)  $\text{Co}(\text{OAc})_2 + \text{P}(n\text{-Bu})_3$  in methanol, 25 °C, 20 bar  $\text{N}_2$ ; (b)  $\text{Co}(\text{OAc})_2 + \text{P}(n\text{-Bu})_3 + \text{octene-1}$  in methanol, 25 °C, 80 bar  $\text{CO}/\text{H}_2$ ; (c) solution b after 17 h of irradiation at 80 °C; (d) solution c after 7 h of thermal reaction at 80 °C. Conditions: 0.0053 M  $\text{Co}(\text{OAc})_2 \cdot 4\text{H}_2\text{O}$ , 0.017 M  $\text{P}(n\text{-Bu})_3$ , 3 M octene-1 in methanol (total volume 700 mL), 80 °C, 80 bar  $\text{CO}/\text{H}_2 = 1$ , 600 W medium-pressure Hg lamp, Pyrex filter. A = methanol, B = CO, ol = octene-1, ald = aldehyde, 1 =  $[\text{Co}(\text{CO})_3(\text{P}(n\text{-Bu})_3)_2]^+$ , 2 =  $[\text{Co}(\text{CO})_4]^-$ , 3 =  $\text{Co}_2(\text{CO})_6(\text{P}(n\text{-Bu})_3)_2$ , 4 =  $\text{HCo}(\text{CO})_3\text{P}(n\text{-Bu})_3$ .

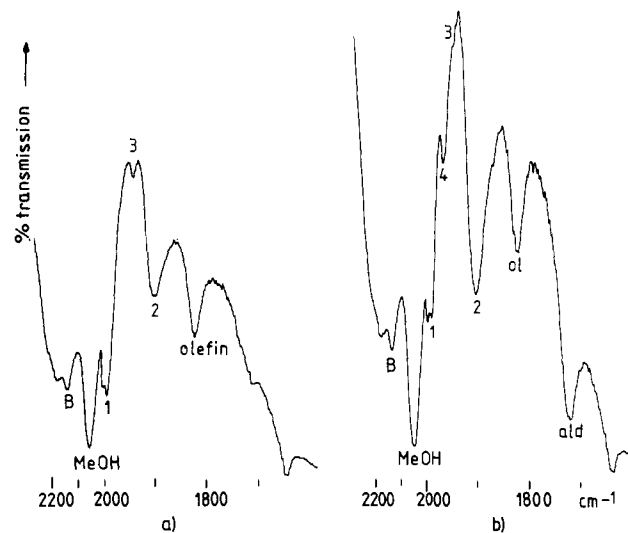
of  $\text{HCo}(\text{CO})_3\text{P}(n\text{-Bu})_3$  (4). Hydroformylation products, which are identified by GLC analysis, are formed simultaneously with these changes of the catalyst as shown by the UV and IR spectra.

When the UV light is turned off the absorptions of the neutral complex 3 slowly disappear; at the same rate those of the cation 1 and the anion 2 grow. No hydroformylation product is formed during dark periods (Figures 3d and 4d). These changes were reversible and could be reproduced several times by alternating irradiation and dark periods.

$[\text{Co}(\text{CO})_3(\text{P}(n\text{-Bu})_3)_2][\text{Co}(\text{CO})_4] + \text{P}(n\text{-Bu})_3$ . The same type of experiment was repeated with the ionic complex  $[\text{Co}(\text{CO})_3(\text{P}(n\text{-Bu})_3)_2][\text{Co}(\text{CO})_4]$  ([1][2]) as the starting catalyst (Figure 5). The spectra show the typical absorptions of the cation 1 and the anion 2. Only a very small amount of 3 is present at 80 °C. The spectra do not change for the first 14 h. When the UV light is turned on, however, the absorptions due to the cation 1 become weaker and a new IR band appears at 1970  $\text{cm}^{-1}$ , which is assigned to the hydride  $\text{HCo}(\text{CO})_3\text{P}(n\text{-Bu})_3$  (4). Interrupting the irradiation



**Figure 4.** UV spectra in the 200–450-nm region during hydroformylation of octene-1 with a  $\text{Co}(\text{OAc})_2/\text{P}(n\text{-Bu})_3$  catalyst: (a)  $\text{Co}(\text{OAc})_2 + \text{P}(n\text{-Bu})_3$  in methanol, 25 °C, 20 bar  $\text{N}_2$ ; (b)  $\text{Co}(\text{OAc})_2 + \text{P}(n\text{-Bu})_3 + \text{octene-1}$  in methanol, 25 °C, 80 bar  $\text{CO}/\text{H}_2$ ; (c) solution b after 17 h of irradiation at 80 °C; (d) solution c after 7 h of thermal reaction at 80 °C. Conditions: 0.0053 M  $\text{Co}(\text{OAc})_2 \cdot 4\text{H}_2\text{O}$ , 0.017 M  $\text{P}(n\text{-Bu})_3$ , 3 M octene-1 in methanol (total volume 700 mL), 80 °C, 80 bar  $\text{CO}/\text{H}_2 = 1$ , 600 W medium-pressure Hg lamp, Pyrex filter.

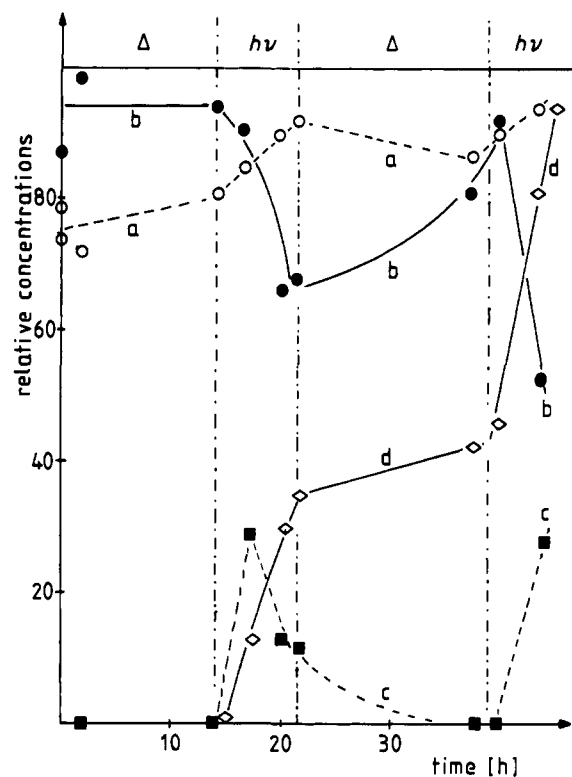


**Figure 5.** IR spectra in the CO stretching region during the hydroformylation of octene-1 with a  $\text{Co}_2(\text{CO})_8/\text{P}(n\text{-Bu})_3$  catalyst: (a) after 2 h of thermal reaction at 80 °C, (b) solution a after 8 h of irradiation. Conditions: 0.0058 M  $\text{Co}_2(\text{CO})_8$ , 0.026 M  $\text{P}(n\text{-Bu})_3$ , 3 M octene-1 in methanol (total volume 600 mL), 80 °C, 85 bar  $\text{CO}/\text{H}_2 = 1$ , 600 W medium-pressure Hg lamp, Pyrex filter. A = methanol, B = CO, ol = octene-1, ald = aldehyde, 1 =  $[\text{Co}(\text{CO})_3(\text{P}(n\text{-Bu})_3)_2]^+$ , 2 =  $[\text{Co}(\text{CO})_4]^-$ , 3 =  $\text{Co}_2(\text{CO})_6(\text{P}(n\text{-Bu})_3)_2$ , 4 =  $\text{HCo}(\text{CO})_3\text{P}(n\text{-Bu})_3$ .

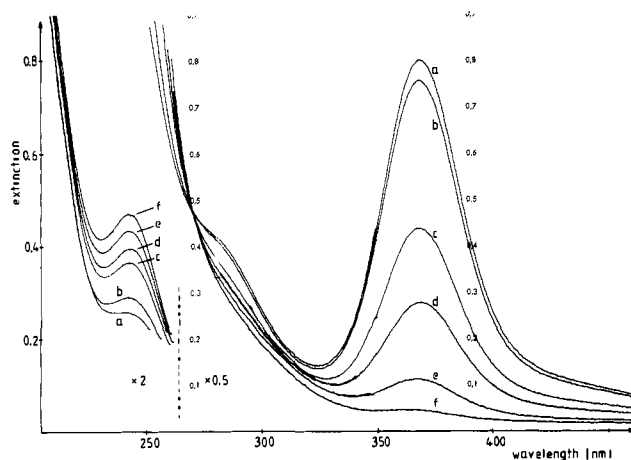
causes the hydride 4 to disappear and the cation 1 to grow. It is important to note that the concentration of 1 decreases during irradiation periods when the hydride 4 and the aldehyde product are formed (Figure 6). The concentration of the anion 2 increases slightly during irradiation.

$\text{Co}_2(\text{CO})_6(\text{P}(n\text{-Bu})_3)_2 + \text{P}(n\text{-Bu})_3$ . In a third experiment  $\text{Co}_2(\text{CO})_6(\text{P}(n\text{-Bu})_3)_2$  was used as the starting catalyst. Under the reaction conditions the neutral complex slowly disproportionates to give the ionic complex [1][2]. This disproportionation occurs thermally and is not significantly affected by irradiation. The photochemical product formation, however, only starts when about 50% of the neutral complex has been converted to the ionic species (eq 4). After about 6 h most of the neutral complex 3 has been disproportionated and the reaction proceeds as described before (Figure 8). In the UV spectrum the conversion of 3 to [1][2] is characterized by an isosbestic point at 270 nm indicating

(11) The absorption spectrum of a methanol solution of  $\text{Co}(\text{OAc})_2 \cdot 4\text{H}_2\text{O}$  in the presence of 80 bar  $\text{CO}/\text{H}_2$  is different from that in air, which exhibits the long wavelength absorption maximum at 520 nm ( $\epsilon \approx 15 \text{ L/mol}\cdot\text{cm}$ ).

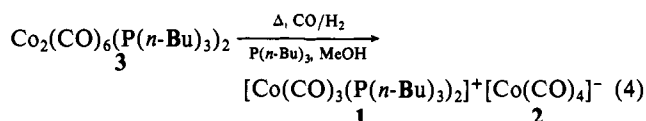


**Figure 6.** Relative concentrations of (a)  $[\text{Co}(\text{CO})_4]^-$ , (b)  $[\text{Co}(\text{CO})_3(\text{P}(n\text{-Bu})_3)_2]^+$ , (c)  $\text{HCo}(\text{CO})_3\text{P}(n\text{-Bu})_3$ , (d) product aldehyde during the hydroformylation of octene-1 with a  $\text{Co}_2(\text{CO})_8/\text{P}(n\text{-Bu})_3$  catalyst. Conditions: 0.0058 M  $\text{Co}_2(\text{CO})_8$ , 0.026 M  $\text{P}(n\text{-Bu})_3$ , 3 M octene-1 in methanol (total volume 600 mL), 80 °C, 85 bar  $\text{CO}/\text{H}_2 = 1$ , 600 W medium-pressure Hg lamp, Pyrex filter.

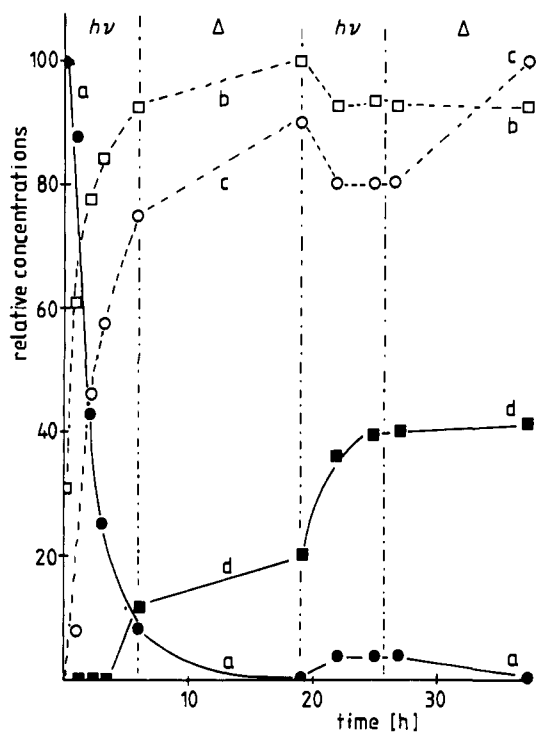


**Figure 7.** UV spectra during the hydroformylation of octene-1 with a  $\text{Co}_2(\text{CO})_8/\text{P}(n\text{-Bu})_3/\text{P}(n\text{-Bu})_3$  catalyst: (a) 0 h, (b) 1 h, (c) 2 h, (d) 3 h, (e) 6 h, (f) 19 h. Conditions: 0.0046 M  $\text{Co}_2(\text{CO})_8$ , 0.021 M  $\text{P}(n\text{-Bu})_3$ , 3 M octene-1 in methanol, (total volume 630 mL), 80 °C, 80 bar  $\text{CO}/\text{H}_2 = 1$ , 600 W medium-pressure Hg lamp.

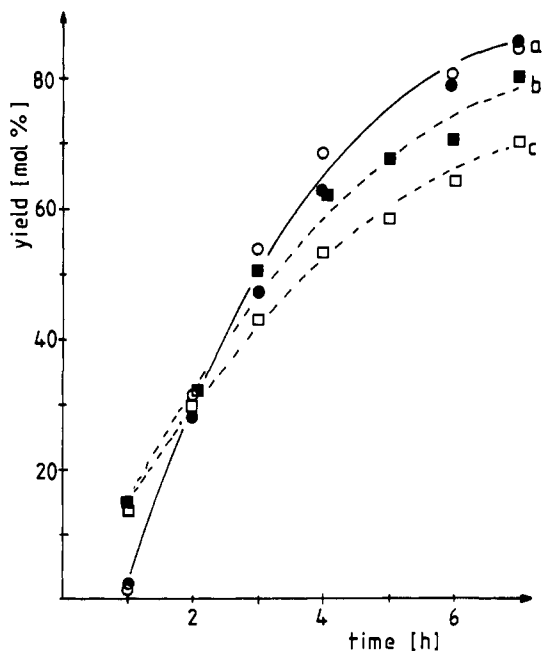
that **1** is formed from **3** without any absorbing intermediate (Figure 7).



**Hydroformylation of Octene-1 with Cobalt Acetate and Cobalt Carbonyl.** When octene-1 is hydroformylated at 85 °C and 80 bar  $\text{CO}/\text{H}_2$  with cobalt acetate as the catalyst precursor in methanol an incubation period of about 15 h is observed, after which the reaction starts yielding 69% conversion after an ad-

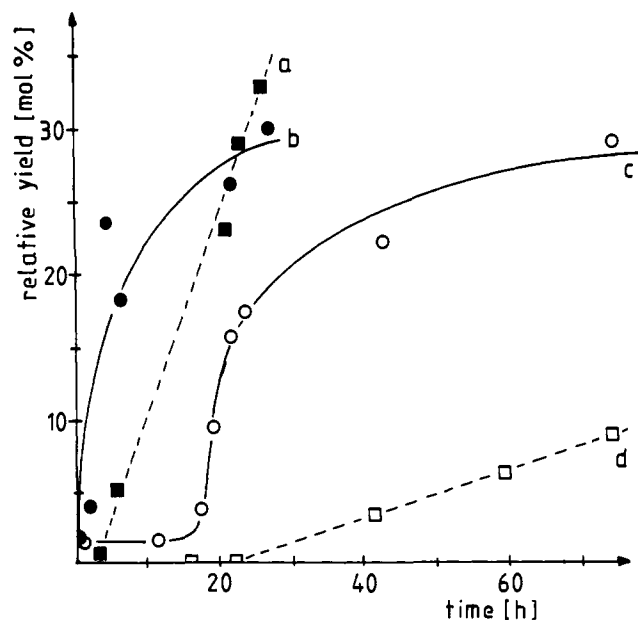


**Figure 8.** Relative concentrations of (a)  $\text{Co}_2(\text{CO})_6(\text{P}(n\text{-Bu})_3)_2$ , (b)  $[\text{Co}(\text{CO})_3(\text{P}(n\text{-Bu})_3)_2]^+$ , (c)  $[\text{Co}(\text{CO})_4]^-$ , (d) product aldehyde during the photochemical hydroformylation of octene-1 with a  $\text{Co}_2(\text{CO})_6(\text{P}(n\text{-Bu})_3)_2/\text{P}(n\text{-Bu})_3$  catalyst. Conditions: 0.0046 M  $\text{Co}_2(\text{CO})_6(\text{P}(n\text{-Bu})_3)_2$ , 0.021 M  $\text{P}(n\text{-Bu})_3$ , 3 M octene-1 in methanol (total volume 630 mL), 80 °C, 80 bar  $\text{CO}/\text{H}_2 = 1$ , 600 W medium-pressure Hg lamp.



**Figure 9.** Hydroformylation of octene-1 with unmodified cobalt catalysts: (a)  $\text{Co}(\text{OAc})_2$ , (○) continuous irradiation, (●) 2 h irradiation and 5 h thermal. No product formation without irradiation for 15 h: (b)  $\text{Co}_2(\text{CO})_8$  thermal (□), (c)  $\text{Co}_2(\text{CO})_8$  continuous irradiation (□). Conditions: 0.0165 M Co, 2.4 M octene-1 in methanol (total volume 500 mL), 85 °C, 80 bar  $\text{CO}/\text{H}_2 = 1$ , 700 W medium-pressure Hg lamp, Pyrex filter.

ditional 7 h (Table I, No. 6). Photochemically the reaction starts almost immediately after the UV light is turned on, and 70% conversion is obtained within only 8 h. When the irradiation is turned off after 2 h of irradiation the reaction proceeds in the dark at approximately the same rate as under continuous irradiation,



**Figure 10.** Hydroformylation of cyclohexene with  $\text{Co}(\text{OAc})_2$  as catalyst: (a) oxo product yield with continuous irradiation in mol % ( $\blacksquare$ ), (b) relative yield of  $[\text{Co}(\text{CO})_4]^-$  with continuous irradiation ( $\bullet$ ), (c) relative yield of  $[\text{Co}(\text{CO})_4]^-$  without irradiation ( $\circ$ ), (d) oxo product yield in mol % without irradiation ( $\square$ ). Conditions: 0.006 M  $\text{Co}(\text{OAc})_2 \cdot 4\text{H}_2\text{O}$ , 3 M cyclohexene in methanol (total volume 700 mL), 80 °C, 80 bar  $\text{CO}/\text{H}_2 = 1$ , 600 W medium-pressure Hg lamp, Pyrex filter.

i.e., the reaction is photoinitiated (Figure 9a). The average activity of the catalyst in the photoinitiated experiment is 6 times higher than in the purely thermal experiment. The ratio of linear to branched products (mostly acetals) is about 70/30 in both the photochemical and thermal runs (Table I, Nos. 5 to 8).

As in the case of propene the absolute rates are higher with the unmodified catalyst than with the phosphine complexes, but the selectivity is lower. It is also noteworthy that under otherwise identical conditions the reaction rates in the solvent methanol are very much higher than in hydrocarbon solvents.<sup>3,18c</sup>

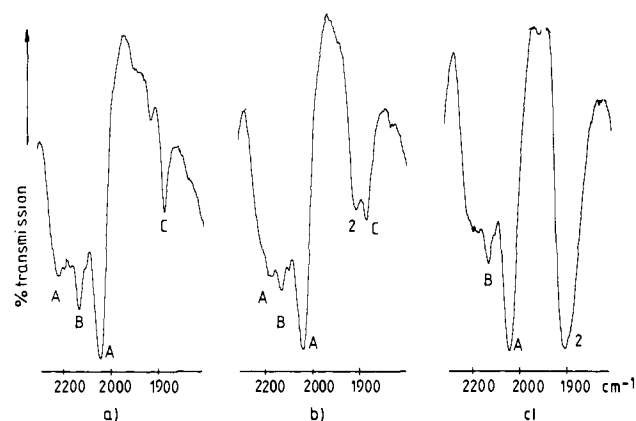
When  $\text{Co}_2(\text{CO})_8$  is used as the starting catalyst, the photochemical and thermal hydroformylation of octene-1 proceed at nearly the same rate and irradiation has no significant effect. The rates in this case are slightly lower than in the photoinitiated reaction with cobalt acetate as catalyst precursor (Figure 9). The product distribution is almost identical, indicating that in both cases the same reaction path is followed (Table I, Nos. 5 to 8).

**Hydroformylation of Cyclohexene with Cobalt Acetate.** When cyclohexene is used instead of octene in the cobalt acetate catalyzed hydroformylation the observations are qualitatively similar. In an experiment without irradiation an incubation period of 17 h is observed, whereas photochemically the reaction starts immediately. The absolute reaction rates with cyclohexene, however, are lower than with octene-1.

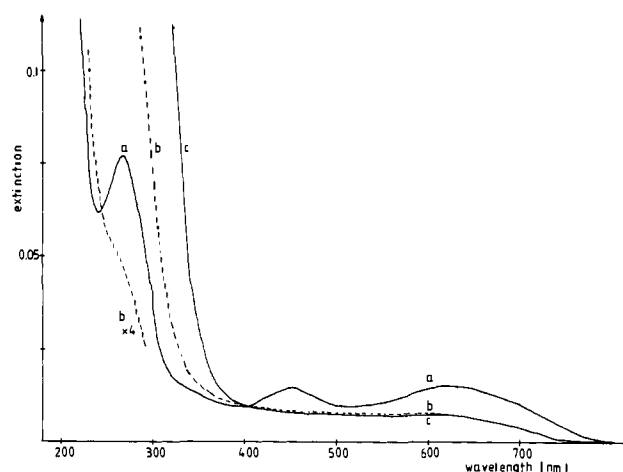
An experiment with alternating irradiation and dark periods reveals another important difference between the hydroformylation of cyclohexene and octene. With cyclohexene the reaction is accelerated compared to the thermal experiment so long as the lamp is turned on (Figure 10a,d). When the lamp is turned off the reaction rate decreases, i.e., the hydroformylation of cyclohexene is photocatalytic.<sup>7</sup>

In the case of unmodified cobalt catalysts the spectroscopic investigation under hydroformylation conditions is complicated by the fact that the UV spectra are more or less featureless and that the IR bands of the cobalt carbonyls are obscured by the strong absorption of the solvent methanol in the same region of the spectrum.

Since the IR and UV spectra were monitored at the same time, any cobalt carbonyl species present at concentrations higher than 5% of the total cobalt should be detected. During the hydroformylation of cyclohexene the IR spectra only show the absorption



**Figure 11.** IR spectra in the CO stretching region during the  $\text{Co}(\text{OAc})_2$ -catalyzed hydroformylation of cyclohexene: (a) starting solution under 80 bar  $\text{CO}/\text{H}_2$  at room temperature, (b) after 1 h photochemical or 19 h thermal reaction at 80 °C, (c) after 21 h photochemical or 88 h thermal reaction at 80 °C. 2 =  $[\text{Co}(\text{CO})_4]^-$ , A = methanol, B = CO, C = cyclohexene. Conditions: 0.006 M  $\text{Co}(\text{OAc})_2 \cdot 4\text{H}_2\text{O}$ , 3 M cyclohexene in methanol (total volume 700 mL), 80 °C, 80 bar  $\text{CO}/\text{H}_2 = 1$ , 600 W medium-pressure Hg lamp, Pyrex filter.



**Figure 12.** UV absorption during the  $\text{Co}(\text{OAc})_2$ -catalyzed hydroformylation of cyclohexene: (a) starting solution immediately after pressurizing to 80 bar  $\text{CO}/\text{H}_2$ , (b) after 1 h irradiation at 80 °C, (c) after 5 h irradiation at 80 °C. Conditions: 0.006 M  $\text{Co}(\text{OAc})_2 \cdot 4\text{H}_2\text{O}$ , 3 M cyclohexene in methanol (total volume 700 mL), 80 °C, 80 bar  $\text{CO}/\text{H}_2 = 1$ , 600 W medium-pressure Hg lamp, Pyrex filter.

at 1910  $\text{cm}^{-1}$  of the anion  $[\text{Co}(\text{CO})_4]^-$  (2) (Figure 11). The relative intensities of this band during the reaction are shown in Figure 10b,c. Thermally the formation of 2 starts only after an induction period of 17 h, after which the thermal formation rate parallels the photochemical one. The rate of aldehyde and acetal formation is always higher photochemically than thermally (Figure 10a,d).

The UV spectrum shows bands with maxima at 610, 450, and 270 nm at the beginning of the reaction belonging to cobalt acetate.<sup>11</sup> The absorption does not change during the first 3 h of thermal treatment, but already after 1 h of irradiation the 270-nm band is covered by a new absorption without a detectable maximum. This featureless absorption increases both with further irradiation and also when the light is turned off after 5 h (Figure 12). Its origin is not completely certain, but the most likely candidate is  $[\text{Co}(\text{CO})_4]^-$  (2), since it is the only CO-containing species detectable by IR spectroscopy and other salts of the anion 2 (e.g.,  $\text{NaCo}(\text{CO})_4$ ) exhibit a similar absorption spectrum. There are no significant amounts of  $\text{Co}_2(\text{CO})_8$  formed, as indicated by the absence of the typical UV maximum at 350 nm.

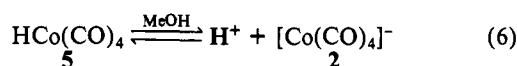
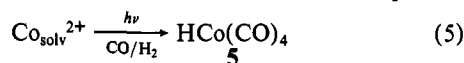
In an analogous experiment without olefin the same spectral features are observed. There is no indication of  $\text{HCo}(\text{CO})_4$ , in contrast to similar experiments in hydrocarbon solvents.<sup>3</sup> Any

$\text{HCo}(\text{CO})_4$  present would, however, be largely dissociated in the methanol.

### Discussion

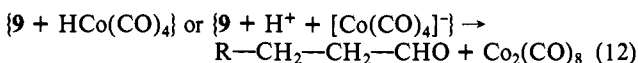
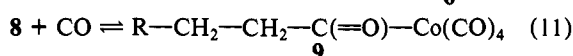
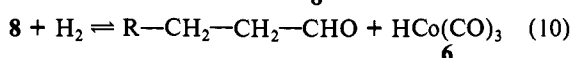
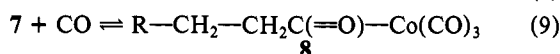
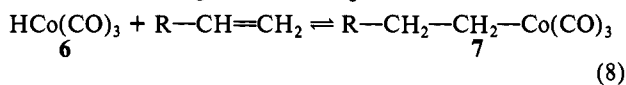
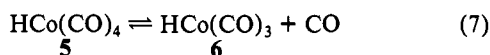
**Unmodified Cobalt Catalysts.** UV light influences the hydroformylation of olefins in methanol solution with cobalt acetate in two ways: (1) It enhances the reduction of the  $\text{Co}^{2+}$  compound to a low valent catalytic active species, as indicated by a reduced induction period. (2) It enhances the actual catalytic reaction when less reactive olefins like cyclohexene are used as substrates. It does not alter the rate of the actual hydroformylation of reactive olefins like octene-1 or propene<sup>12</sup> after the incubation time.

The first effect, the photochemical reduction of cobalt acetate, leads to the anion **2** as the only detectable product. This reduction results probably first in the formation of  $\text{HCo}(\text{CO})_4$  (**5**), which then dissociates to  $\text{H}^+$  and the anion **2**.<sup>13,14</sup> This assumption is

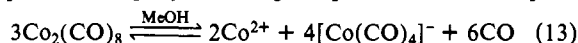


based on the argument that the reaction rate of the photochemical octene hydroformylation is higher with cobalt acetate than with  $\text{Co}_2(\text{CO})_8$  (Figure 9). If  $\text{Co}_2(\text{CO})_8$  or  $[\text{Co}(\text{CO})_4]^-$  were formed first and then reacted to give  $\text{HCo}(\text{CO})_4$ , the hydroformylation rate with cobalt acetate would be lower than with  $\text{Co}_2(\text{CO})_8$ . From the experiments performed so far, no detailed mechanism can be given for the reduction. The low extinction coefficients of the long wavelength absorptions of a  $\text{Co}^{2+}$  solution under  $\text{CO}/\text{H}_2$  pressure ( $\epsilon(610 \text{ nm}) \approx \epsilon(450 \text{ nm}) \approx 50 \text{ L/mol}\cdot\text{cm}$ ) indicate a ligand field transition for these bands. It is possible that only a small amount of a low valent cobalt compound needs to be formed in a photochemical step in order to initiate the reduction. Afterwards the reduction is completed rapidly in an autocatalytic thermal reaction, as had been postulated for a similar example with  $\gamma$  radiation.<sup>15</sup>

The hydride **5** is generally assumed to initiate the hydroformylation reaction via a catalytic cycle as summarized in eq 7–12.<sup>16,17</sup>



According to this sequence the 16 electron species **6** acts as the chain carrier (eq 8–10), whereas 11 and 12 lead to a termination of the catalytic cycle via the formation of  $\text{Co}_2(\text{CO})_8$ . Dicobalt octacarbonyl is unstable in the presence of methanol and will disproportionate rapidly according to eq 13.<sup>18</sup> There are reports



(12) For a compilation of olefin reactivities in the hydroformylation reaction see ref 1d.

(13) "Gmelin Handbuch der Anorganischen Chemie", 8th ed.; "Kobalt-Organische Verbindungen 1"; p 684.

(14) Ungvary, F.; Sisak, A.; Marko, L. *J. Organomet. Chem.* **1980**, *188*, 373.

(15) Laege, J.; Thelen, G.; Saus, A. *J. Mol. Catal.* **1981**, *11*, 23–26.

(16) (a) Breslow, D. S.; Heck, R. F. *Chem. Ind. (London)* **1960**, 467; *J. Am. Chem. Soc.* **1961**, *83*, 4023. (b) Wender, I.; Sternberg, H. W.; Orchin, M. *Ibid.* **1953**, *75*, 3041.

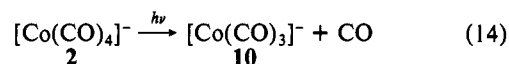
(17) (a) Davidson, P. J.; Hignett, R. R.; Thompson, D. T. In "Catalysis", Kemball, C., Ed.; Chemical Society: London, 1977; Vol. 1, p 369. (b) Orchin, M.; Rupilius, W. *Catal. Rev.* **1972**, *6*, 85. (c) Kaesz, H. D.; Saillant, R. B. *Chem. Rev.* **1972**, *72*, 231.

in the literature that under high CO pressure the equilibrium (eq 13) shifts to the left.<sup>18d</sup> Under the conditions used in our experiments, however, no  $\text{Co}_2(\text{CO})_8$  was detected.

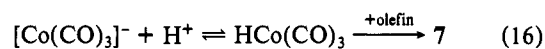
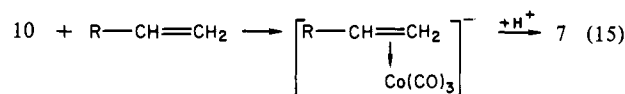
When  $\text{Co}_2(\text{CO})_8$  itself is used as the starting catalyst, it is already disproportionated according to eq 13 before the actual reaction starts. Nevertheless hydroformylation occurs with  $\text{Co}_2(\text{CO})_8$  in methanol. Therefore there must be a pathway for the disproportionated complex to enter the catalytic cycle.<sup>19</sup> One possibility is the formation of **5** via equilibrium **6** and **6** via equilibrium **7**. The stationary concentrations of **5** and **6** are very small, since **5** is a relatively strong acid in protic solvents. These small concentrations, however, suffice to initiate efficiently the hydroformylation of reactive olefins such as octene-1 or propene. The reaction of these  $\alpha$ -olefins with the hydride **6** is known *not* to be rate determining in the catalytic cycle.<sup>17a,20</sup> The reaction of the hydride **5** or **6**, respectively, is rate determining with less reactive olefins, like cyclohexene.<sup>17a,20a</sup>

Therefore it seems logical to deduce that the entrance into the catalytic cycle via the hydride **6** is influenced by UV light, since the hydroformylation of cyclohexene is photocatalytic and that of octene-1 is not photocatalytic.

The only cobalt carbonyl species which can be detected by IR spectroscopy during the hydroformylation reaction is the anion **2**, which is also likely to be responsible for the unstructured absorption in the near-UV region. Thus the anion absorbs part of the light during the photochemical reaction. Although the primary photoreactions of  $[\text{Co}(\text{CO})_4]^-$  are not yet described, it seems conceivable that it will lose one CO upon irradiation (eq 14). The unsaturated anion **10** may now attack the olefin directly



(eq 15) or, since it is probably a weaker base than **2**, via the intermediate formation of  $\text{HCo}(\text{CO})_3$  (eq 16), thus offering an additional pathway for the olefin to enter the catalytic cycle.



This mechanism is consistent with our experimental data and with other observations described in the literature, and it seems to us the most straightforward. Our experiments, however, do not exclude other less conventional possibilities.

**Phosphine-Modified Cobalt Catalysts.** Two major differences between the hydroformylation with the phosphine modified and the unmodified cobalt catalyst are observed: (a) the reaction rates differ by an order of magnitude and (b) the isomeric distribution of the reaction products is different.

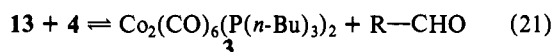
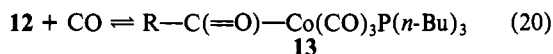
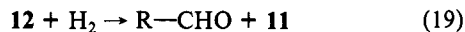
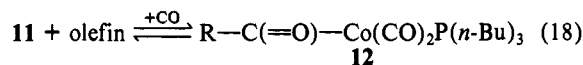
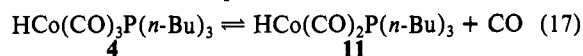
These findings require different active catalytic intermediates for the two systems. Therefore  $\text{HCo}(\text{CO})_4$  and  $\text{HCo}(\text{CO})_3$  formed via eq 6 or 7 cannot be responsible for the major part of the hydroformylation reaction with the Co/phosphine catalyst. Obviously the  $\text{H}^+$  concentration of the solution in the presence of a large excess of phosphine is too low to shift equilibrium **6** to the left.  $\text{HCo}(\text{CO})_4$  is of course a much stronger acid than its phosphine-modified analogue **4**.<sup>17c</sup> The most conventional assumption is that the hydride  $\text{HCo}(\text{CO})_3\text{P}(n\text{-Bu})_3$  (**4**) is the active catalyst and that it initiates the hydroformylation via the known catalytic cycle (eq 17–21<sup>20a,21</sup>). Our spectroscopic data are in

(18) (a) Wender, I.; Sternberg, H. W.; Orchin, M. *J. Am. Chem. Soc.* **1952**, *74*, 1216. (b) Hieber, W.; Sedlmeier, J.; Abeck, W. *Chem. Ber.* **1953**, *86*, 700. (c) Wender, I.; Metlin, S.; Ergun, S.; Sternberg, H. W.; Greenfield, H. *J. Am. Chem. Soc.* **1956**, *78*, 5401. (d) Bortinger, A.; Busse, P. J.; Orchin, M. *J. Catal.* **1978**, *52*, 385.

(19) Reference 14 describes the stoichiometric hydroformylation with  $[\text{Co}(\text{CO})_4]^-$  in the presence of  $\text{H}^+$ .

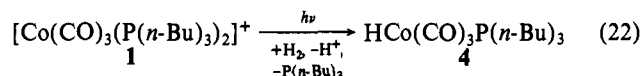
(20) (a) Whyman, R. *J. Organomet. Chem.* **1974**, *66*, C23; **1974**, *81*, 97. (b) Alemdaroglu, N. H.; Penninger, J. L. M.; Oltay, E. *Monatsh. Chem.* **1976**, *107*, 1154.

agreement with this assumption.



Equations 17–21 represent thermal reactions. The photochemical reaction must be the formation of the hydride **4**, since its concentration increases during periods of irradiation and decreases during dark periods (Figure 6). A comparison of the experiments with different starting complexes shows that, independent of the original cobalt source, the cationic complex **1** is the main photoreactive species.<sup>22</sup>

This is even better demonstrated with cobalt acetate as the starting complex. Upon the addition of synthesis gas it immediately forms the cation **1** (eq 3), which is then the only light absorbing species present. Upon irradiation cation **1** is partly converted to the hydride **4**, which initiates the hydroformylation (eq 22). When the reaction proceeds, the neutral complex **3** is



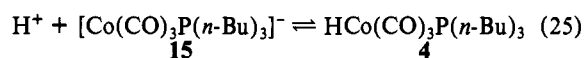
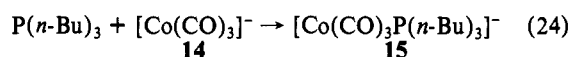
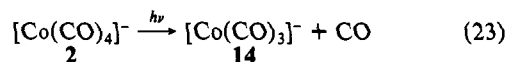
(21) (a) Tucci, E. R. *Ind. Eng. Chem., Prod. Res. Dev.* **1968**, *7*, 33. Hershman, A.; Craddock, J. H. *Ibid.* **1968**, *7*, 225. (c) Slaugh, L. H.; Mullineaux, R. D. *J. Organomet. Chem.* **1968**, *13*, 469. (d) van Boven, M.; Alemdaroglu, N. H.; Penninger, J. M. L. *Ind. Eng. Chem. Prod. Res. Dev.* **1975**, *14*, 259.

(22) In agreement with our experiments it was reported that neither the cation **1** nor the anion **2** catalyze the hydroformylation in a thermal reaction, see ref 17a, p 372.

formed via eq 21, which slowly disproportionates consecutively to give back the cation **1** and the anion **2** (eq 4). Thus the concentration of the anion **2** increases during the reaction (cf. Figure 6).

The neutral complex **3** obviously absorbs part of the light. Nevertheless it does not seem to influence the photochemical hydroformylation under the applied conditions. This is confirmed in the experiment with **3** as the starting complex, in which the hydroformylation only starts after 5 h, when most of the neutral carbonyl **3** is already disproportionated to **1** and **2**.

Careful inspection of the UV spectra taken during the Co(OAc)<sub>2</sub> experiment reveals that there is an increasing background absorption besides the well-defined absorption maxima of the complexes **1** and **3** at 245 and 365 nm, respectively. This featureless background absorption is likely to belong to the anion **2**. Therefore a photoreaction of the anion **2** must be taken into account. For the above-mentioned reasons this photoreaction must be different from that in the absence of phosphine (eq 14 to 16). A sequence as in eq 23–25 would seem feasible and would explain



some of the unexpected irregularities in the [Co(CO)<sub>4</sub>]<sup>-</sup> concentration during the reaction with **3** as the starting catalyst (Figure 8). The similarities of the results with Co(OAc)<sub>2</sub> and [Co(CO)<sub>3</sub>P(*n*-Bu)<sub>3</sub>]<sub>2</sub>[Co(CO)<sub>4</sub>] as starting catalysts, the solutions of which contain rather different concentrations of the anion **2**, do indicate that the photoreaction of **2** is only of minor importance.

**Acknowledgment.** We would like to thank Mr. Albert van de Berg and Mr. Eleftherios Eleftheriadis for experimental assistance and the referees for their valuable comments.